

Document 0104-0011
 AeroLEDs LLC
 8475 W Elisa Street
 Boise, ID 83709
 Phone: (208) 850-3294
www.aeroleds.com
sales@aeroleds.com

Installation Guide:
Microsun
P/N 01-1170-A
LED light with
built-in pulse recognition mode

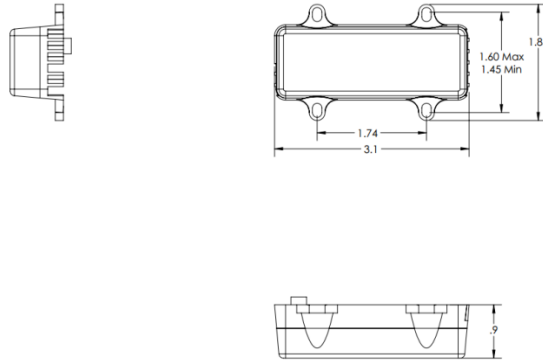

Operating Instructions:

Operational Voltage: 14 & 28 Volt Systems
Input Current: 1.5A at 14V, 0.75A at 28V

EQUIPMENT LIMITATIONS:

Mount in bezel mounting plate with circuit breaker or fuse appropriate for rated current. The procedures contained herein are not intended to conflict with the procedures set forth by aircraft and engine manufacturers, nor do they supersede the FAA approved manuals and FAA regulations. If necessary, consult AC 43.13-1B for guidance on acceptable methods, techniques, and practices.

CONTINUED AIRWORTHINESS:

The Microsun LED light assembly is designed with 3 high power LEDs mounted behind a lens. Should any one LED fail, the unit must be replaced.

Interval	Description	Notes
50 hr.	<ul style="list-style-type: none"> Perform function check on landing light(s) 	Landing lights are not field repairable and should be sent to manufacturer for repair/replacement if defective
100 hr.	<ul style="list-style-type: none"> Perform function check on landing 	Landing lights are not field repairable and should be sent to manufacturer for

	light(s) / replace unit if defective <ul style="list-style-type: none"> Inspect for discoloration of lens Inspect mounting for security Inspect all connectors for good engagement Inspect wiring for chaffing / defects 	repair/replacement if defective
Annually	<ul style="list-style-type: none"> Perform function check on landing light(s) / replace unit if defective Inspect for discoloration of lens Inspect mounting for security Inspect all connectors for 	Landing lights are not field repairable and should be sent to manufacturer for repair/replacement if defective

	<p>good engagement</p> <ul style="list-style-type: none"> Inspect wiring for chaffing / defects 	
--	--	--

5. Install an appropriate aircraft approved switch and circuit breaker of correct rating for the lights installed for the pulse function. Original landing light switch/switches may be used, however, the circuit breakers are to be replaced with one(s) of appropriate rating for the lights installed.
6. Placard switches appropriately.
7. Power up aircraft and verify proper operation of Microsun LED light, in both pulsing and steady functions (as appropriate to the installation)
8. Using the appropriate aircraft maintenance manual, verify that the light angle has not changed, and is oriented & aimed in accordance with manufacturer's instructions.
9. Perform EMI test to verify there is no interference caused by light installation.
10. Reinstall cowlings or lens covers as needed.
11. Fill out and submit appropriate form 337 for work accomplished (unless installed under STC), and enter appropriate logbook entry detailing work for certified aircraft.
12. Weight & balance change from standard position light assemblies to LED landing light assemblies is considered negligible. However, if additional power supplies or pulse function controllers were removed at this time, the weight & balance is to reflect those changes, and actual weight and locations are to be used for calculating changes.

INSTALLATION PROCEDURES:

1. The installation procedure described in the following text is for a single light installation, but the procedure is identical for multiple light installations. The pulsing function of the light(s) is a self-contained feature, and does not require the use of an externally mounted pulse light controller.
2. Remove cowlings and/or landing light lens to gain access to light assemblies.
3. Route wire (minimum 20 AWG) from switch location to LED light assemblies through wings and/or cowling, securing as needed using tie-wraps or equivalent means to secure wire bundles.
4. Install suitable aircraft approved connectors to wires coming from landing light assemblies and wires routed from switch using wiring diagram shown on page 2.

Figure 1

Wiring Diagram for single LED Microsun light

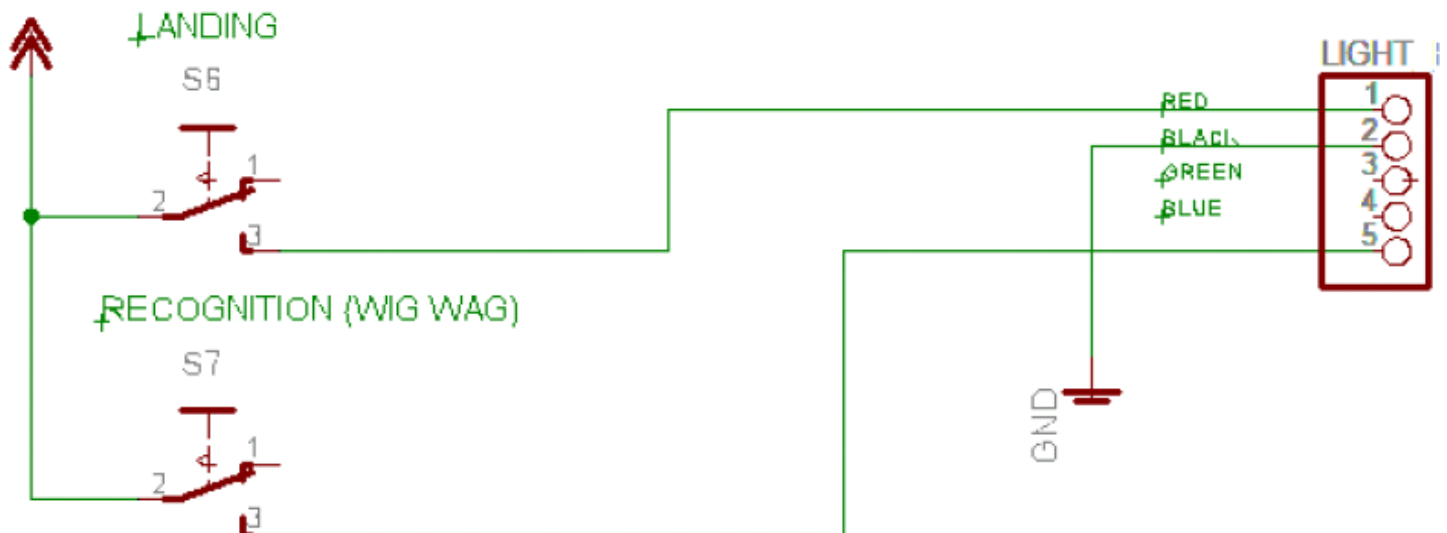

Figure 2

Wiring Diagram for dual LED Microsun lights

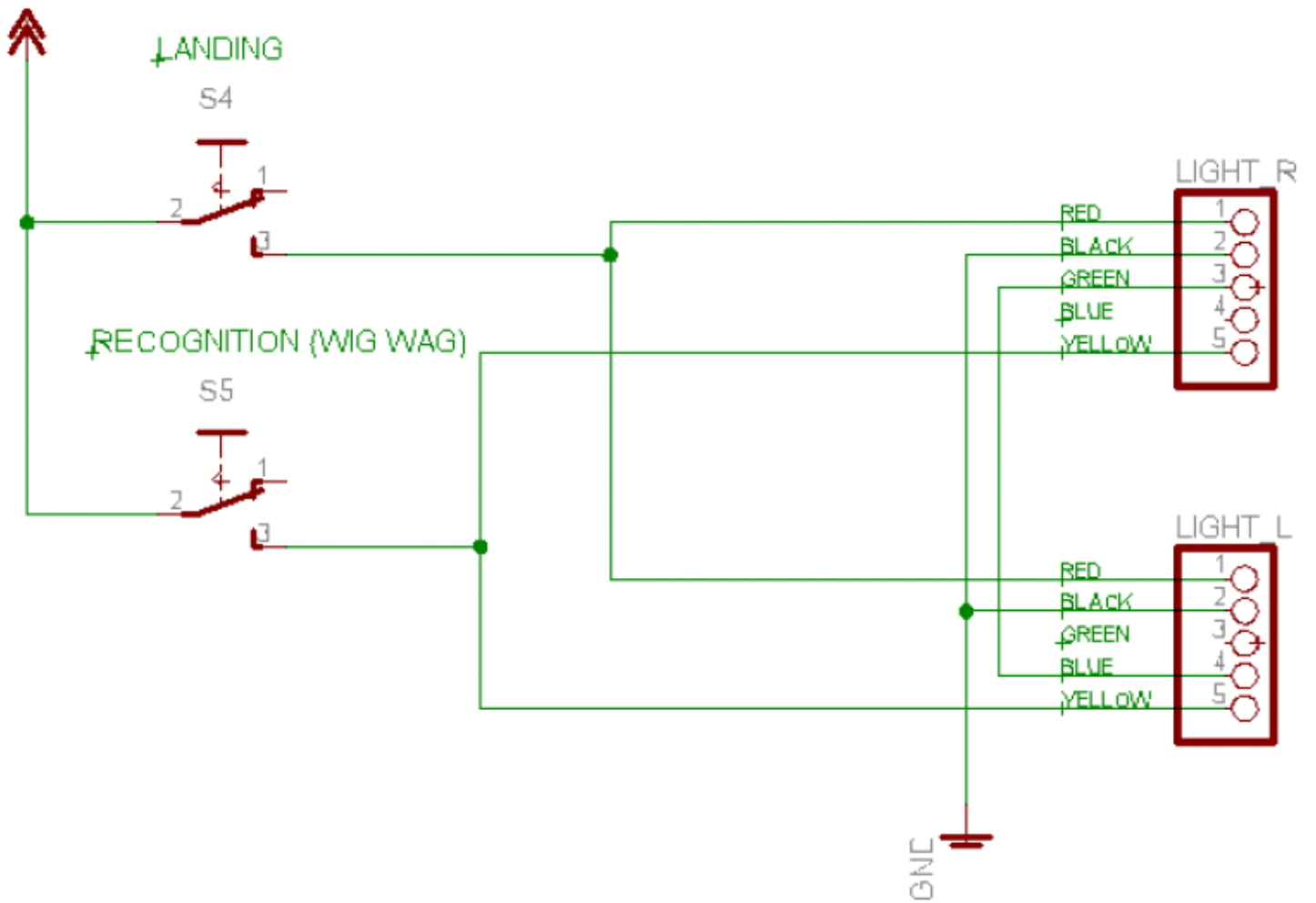
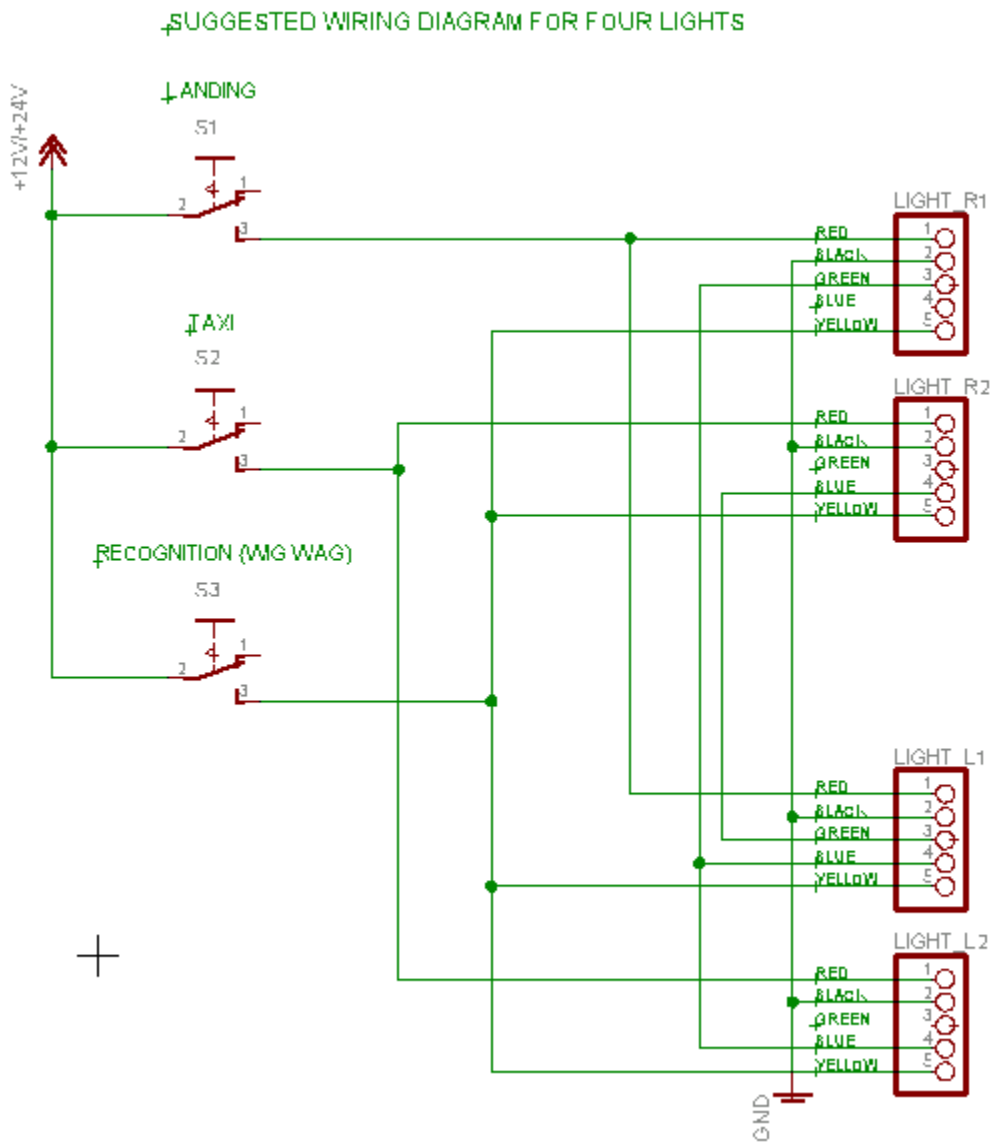

Figure 3

Wiring Diagram for four LED Microsun light assemblies



DO-160E Section	Compliance Level
4	F2
5	F2
6	C
8	U
9	H
10	S
11	F
12	D
13	F
14	S
15	A
16	Z
17	A
18	Z
19	ZC
20	RR
21	H
22	A2E2

INSTALLATION INSTRUCTIONS REVISION RECORD SHEET

Revision Number	Effective Date	Inserted By	Page Numbers Revised
IR	10/07/2016	Dean Wilkinson	All